



# BEVERAGE-AIR

Project: \_\_\_\_\_

AIA#

Item: \_\_\_\_\_

Location: \_\_\_\_\_

SIS#

Approved: \_\_\_\_\_

## MMR MARKETMAX REFRIGERATOR

### MMR44HC White Hinged Double Glass Door

### Hydrocarbon Series

**MODELS:**

**MMR44HC-1-W**

MMR44HC Hinged Glass Door: Merchandiser Series



**MMR44HC-1-W**

**3 Year Parts/Labor Warranty  
Additional 2 Year Compressor Warranty**

### CABINET CONSTRUCTION

- Exterior finish is heavy duty steel with a white baked on durable coating
- Heavy duty interior construction includes white coated steel walls
- Modern one-piece grille
- Full electronic control
- Refrigerator have double pane lowE argon filled glass doors
- 120° stay open door feature, with automatic stay open feature
- Snap-in gaskets, easy to remove for cleaning or replacement
- Field reversible doors
- LED lighting, standard
- Ten (10) heavy duty epoxy coated wire shelves
- Four (4) shelf clips included per shelf
- Anti-microbial door handles
- Brightly lighted sign panel
- Self-contained bottom mount refrigeration system
- Maintains product temperatures between 36°F and 38°F

### OPTIONS & ACCESSORIES

- Black or stainless steel exterior option
- Black or stainless steel interior option
- Wine models available
- Wine thermometer
- Shelves black or white
- Stainless steel clips
- Flow track
- Gravity track
- Price tag molding
- Electronic lock models (swing doors only)
- 6" legs
- 3" or 6" Casters
- Door locks
- Custom signage & decals
- Remote option

### REFRIGERATION SYSTEM

- Refrigeration system uses R290 refrigerant to comply with all environmental concerns
- Automatic, non-electric defrost
- Epoxy coated evaporator coil



3779 Champion Blvd., Winston-Salem, NC 27105  
1-888-845-9800 Fax: 1-336-245-6453  
Beverage-Air.com sales@bevair.com



# BEVERAGE-AIR

## MMR Refrigerator - Double Glass Door

Models: MMR44HC-1-W

MODEL	MMR44HC-1-W
<b>EXTERNAL DIMENSIONAL DATA</b>	
Width Overall	47"
Depth Overall with Handle	33 1/2"
Height Overall	78"
Number of Doors	2
Depth With Door Open 90°	53 1/2"
Door Opening (in)	20 1/8" x 52 5/8"
<b>INTERNAL DIMENSIONAL DATA</b>	
NET Capacity (cubic ft.)	40.2
Internal Width Overall (in)	44"
Internal Depth Overall (in)	26"
Internal Height Overall (in)	61 5/8"
Internal Height Useable (in)	53"
Number of Shelves	10
<b>ELECTRICAL DATA</b>	
Full Load Amperes 115/60/1	5
<b>REFRIGERATION DATA</b>	
Horsepower	1/3
Capacity (BTU/Hr)*	2392
<b>WEIGHT DATA</b>	
Gross Weight (Crated lbs)	544 lbs
Height - Crated	85"
Width - Crated	49"
Depth - Crated	36"

### Model Views

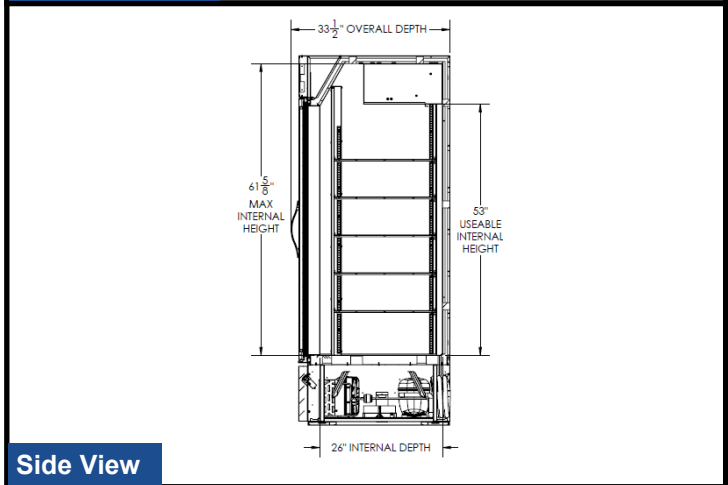
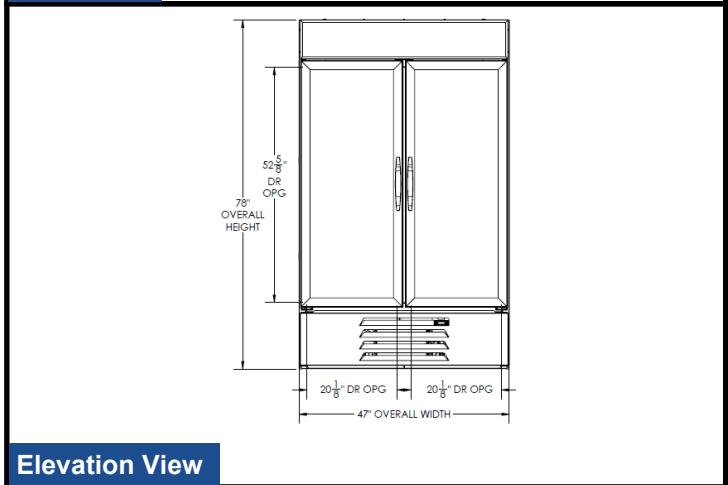
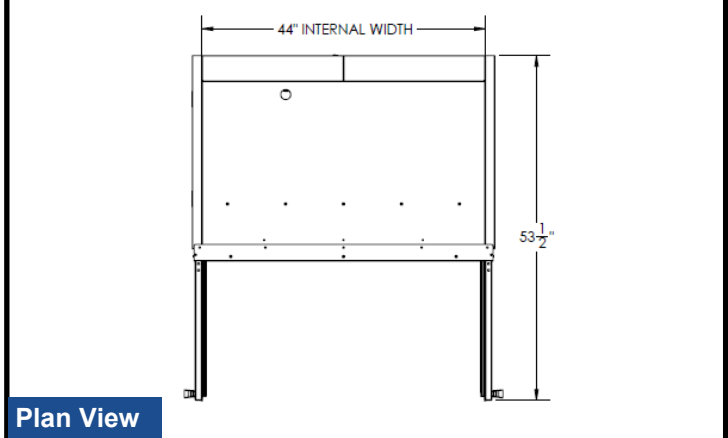

### ELECTRICAL CONNECTION



115/60/1  
NEMA-5-15P

Units pre-wired at factory and include 8' long cord and plug set.



an Ali Group Company



The Spirit of Excellence

3779 Champion Blvd., Winston-Salem, NC 27105  
1-888-845-9800 Fax: 1-336-245-6453  
Beverage-Air.com sales@bevair.com